



DATI TECNICI / TECHNICAL DATA

Fluido / Fluid	Aria / Air
Pressione Max / Maximum pressure	15 bar
Temperatura / Temperature	-10 / +50° C
Campo di regolazione / Regulation range	0-2bar 0-4bar 0-8bar standard 0-12bar
Portata a 6 bar con Δp 1bar / 6bar flow rate with Δp 1bar	600NI/min
Attacco manometro / Manometer fastening	1/8

CHIAVE DI CODIFICA / ORDERING CODE

XR 0,0,0,0

CAMPO DI REGOLAZIONE
REGULATION RANGE

- 1=0-2bar
- 2=0-4bar
- 3=0-8bar STANDARD
- 4=0-12bar

FILETTO / THREAD

- 1=G 1/8 (TAGLIA 0)
- 2=G 1/4 (TAGLIA 0)

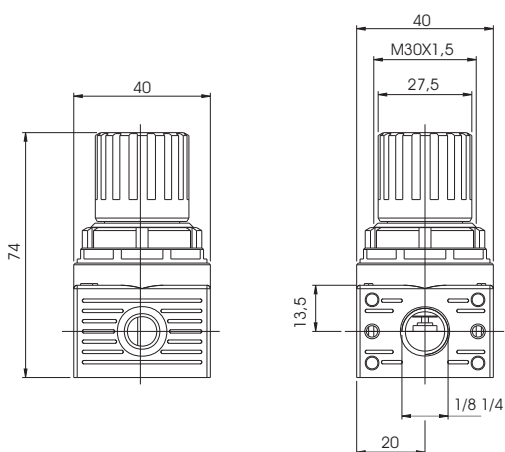

COMPONENTI / COMPONENTS

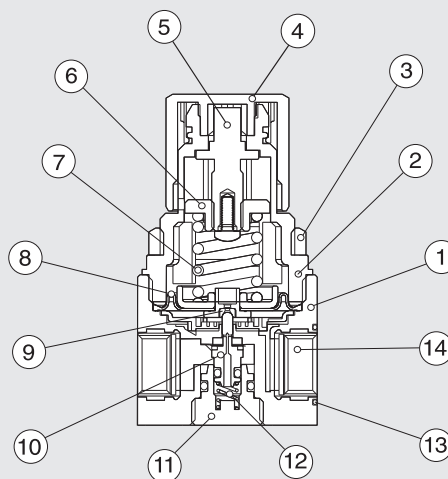

1	corpo / body	tecnopolimero / technopolymer
2	campana / bell	tecnopolimero / technopolymer
3	ghiera di fissaggio / fixing nut	tecnopolimero / technopolymer
4	manopola / knob	tecnopolimero / technopolymer
5	vite di registro / register screw	ottone / brass
6	chiocciola / female screw	ottone / brass
7	molla di registro / register spring	acciaio / steel
8	membrana / membrane	
9	guarnizione / seal	NBR
10	otturatore / shutter	NBR
11	tappo / plug	tecnopolimero / technopolymer
12	molla / spring	acciaio inox / stainless steel
13	o-ring	NBR
14	inserto filettato / threaded insert	ottone / brass